

3/4" RIB TYPICAL DETAILS OVER 15/32" PLYWOOD

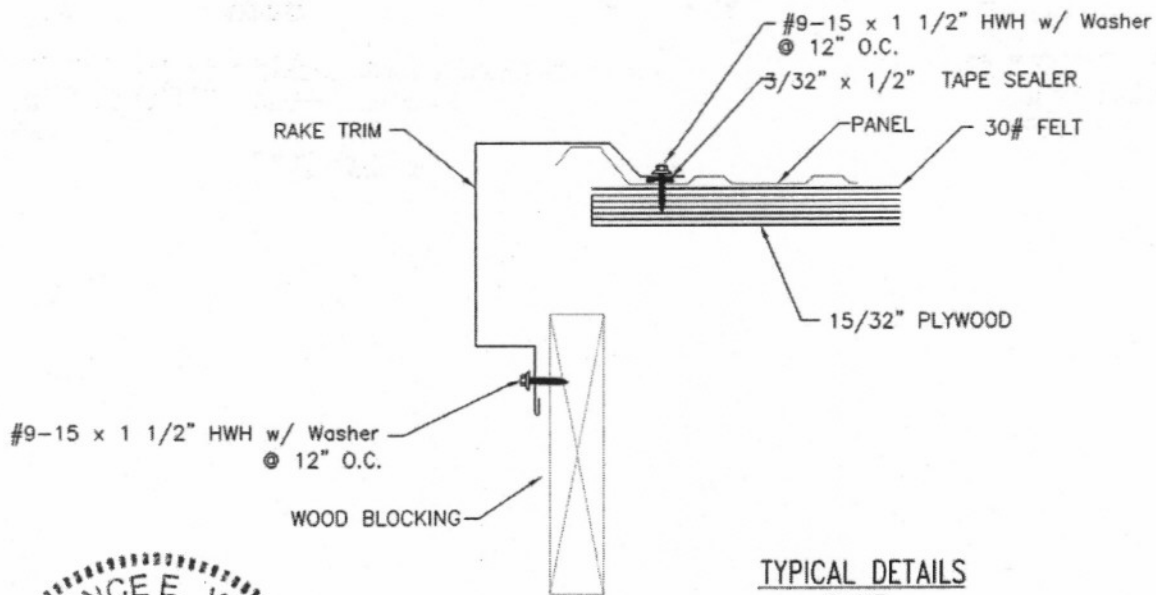
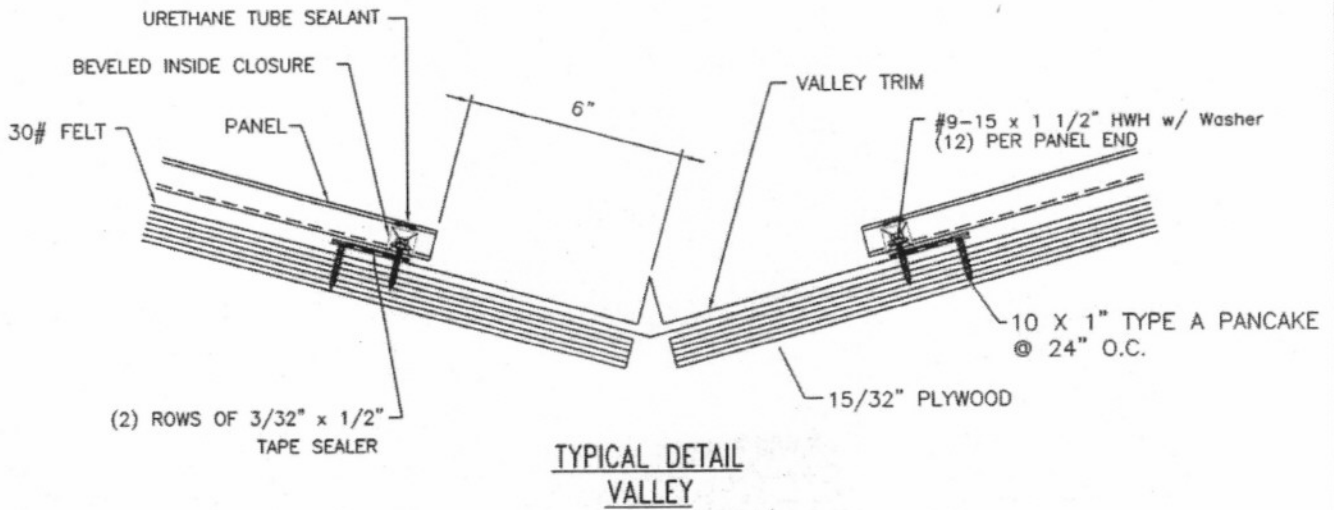

State of Florida  
C.O.A.  
# 29778

JOB NO: -----

DWG NO: D1

REV NO: 0

3/4" RIB TYPICAL DETAILS OVER 15/32" PLYWOOD

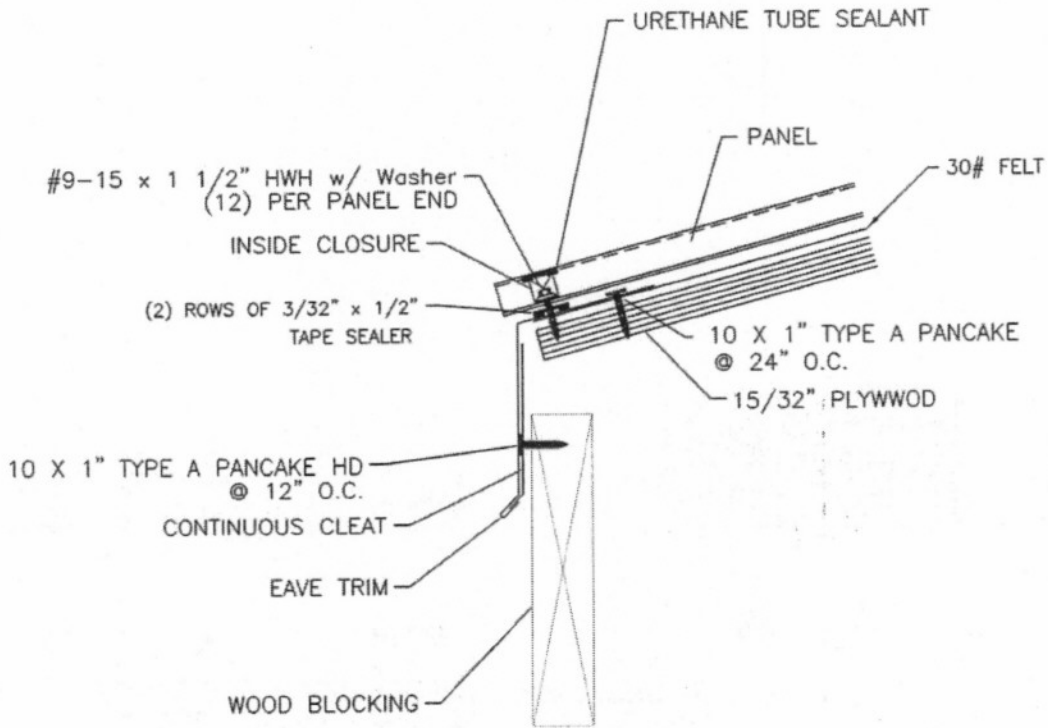

TYPICAL DETAILS  
EAVE

State of Florida  
C.C.A.  
# 22978



JAN 24 2012

JOB NO: ----

DWG NO: D2

REV NO: 0

3/4" RIB TYPICAL DETAILS OVER 15/32" PLYWOOD

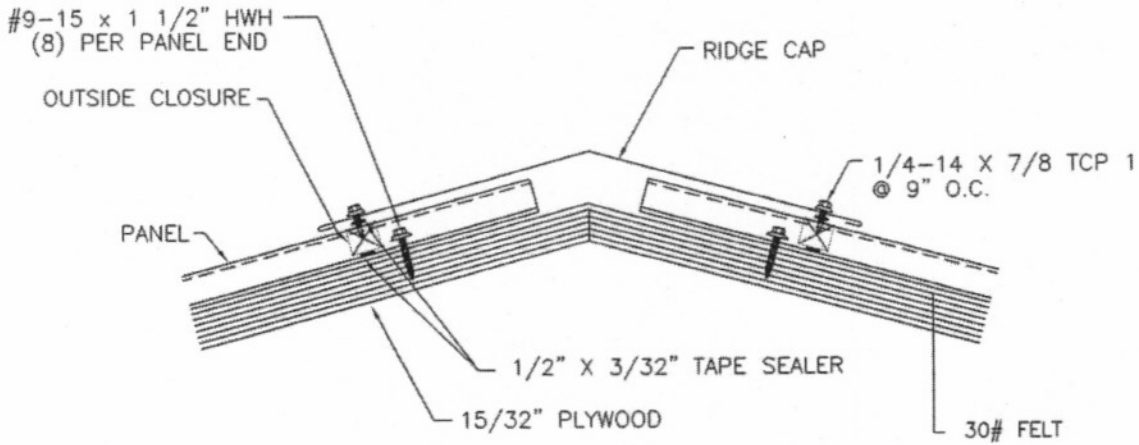

TYPICAL DETAILS  
RIDGE

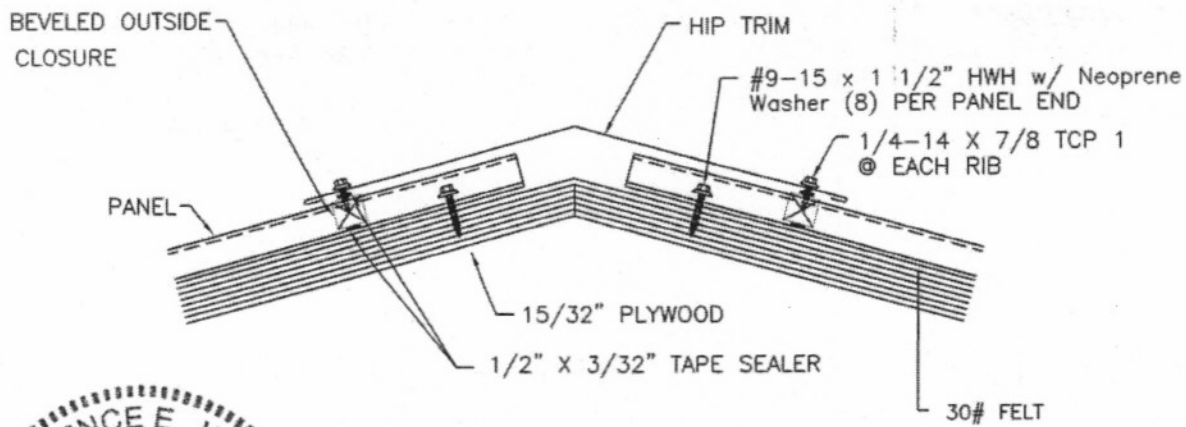

TYPICAL DETAILS  
HIP



State of Florida  
C.O.A.  
# 25773

JAN 24 2012

JOB NO:	----
DWG NO:	D3
REV NO:	0

3/4" RIB TYPICAL DETAILS 15/32" PLYWOOD

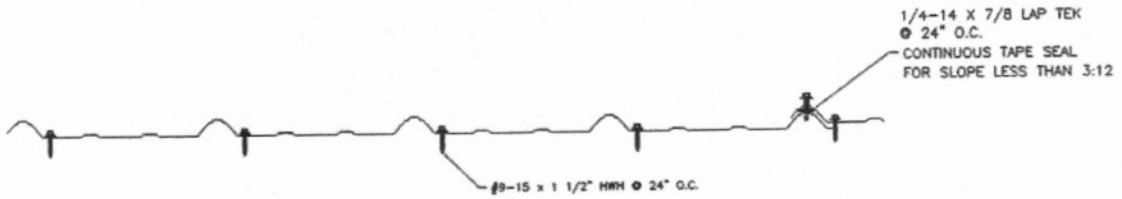

TYPE 1 FASTENER PATTERN

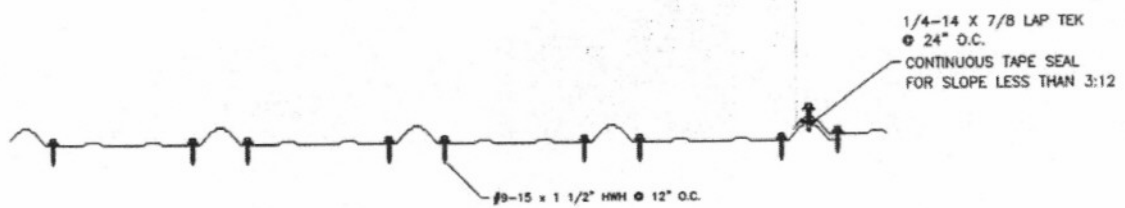

TYPE 2 FASTENER PATTERN

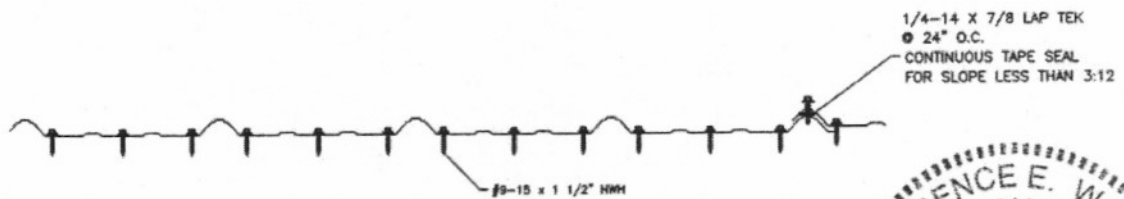

FASTENER PATTERN AT EAVE & VALLEY



JOB NO. JAN 24 2012

DWG NO: D4

REV NO: 0